

Model: NEMA17 Stepper Motor - JK42HM (0.9 degree)

General Specification:

Step Accuracy ----- $\pm 5\%$
 Resistance Accuracy ----- $\pm 10\%$
 Inductance Accuracy ----- $\pm 20\%$
 Temperature Rise ----- 80°C MAX.
 Ambient Temperature Range ----- $-20^{\circ}\text{C} \sim +50^{\circ}\text{C}$
 Storage Temperature Range ----- $-30^{\circ}\text{C} \sim +60^{\circ}\text{C}$
 Insulation Resistance ----- $100\text{M } \Omega \text{ MIN. } 500\text{V DC}$
 Dielectric Strength ----- $500\text{V AC } 1\text{min}$
 Radial Play ----- $0.02\text{mm MAX. (450g Load)}$
 End Play ----- $0.08\text{mm MAX. (450g Load)}$
 Max. radial force ----- 28N
 Max. axial force ----- 10N

Electrical Specification:

Model No.	Step Angle	Motor Length	Current /Phase	Resistance /Phase	Inductance /Phase	Holding Torque	Lead wires	Detent Torque	Rotor Inertia	Motor weight
	($^{\circ}$)	(L)mm	A	Ω	mH	kg.cm	No.	g.cm	g.cm^2	Kg
JK42HM34-0956	0.9	34	0.95	4.2	4	1.58	6	200	35	0.22
JK42HM34-0606	0.9	34	0.6	10	9.5	1.58	6	200	35	0.22
JK42HM34-0316	0.9	34	0.31	38.5	33	1.58	6	200	35	0.22
JK42HM34-1334	0.9	34	1.33	2.1	4.2	2.2	4	200	35	0.22
JK42HM40-1206	0.9	40	1.2	3.3	3.4	2.59	6	220	54	0.28
JK42HM40-0806	0.9	40	0.8	7.5	6.7	2.59	6	220	54	0.28
JK42HM40-0406	0.9	40	0.4	30	30	2.59	6	220	54	0.28
JK42HM40-1684	0.9	40	1.68	1.65	3.2	3.3	4	220	54	0.28
JK42HM48-1206	0.9	48	1.2	3.3	4	3.17	6	250	68	0.35
JK42HM48-0806	0.9	48	0.8	7.5	10	3.17	6	250	68	0.35
JK42HM48-0406	0.9	48	0.4	30	38	3.17	6	250	68	0.35
JK42HM48-1684	0.9	48	1.68	1.65	4.1	4.4	4	250	68	0.35

***Note:** We can also manufacture products according to customer's requirements.

Dimensions:
(Unit=mm)

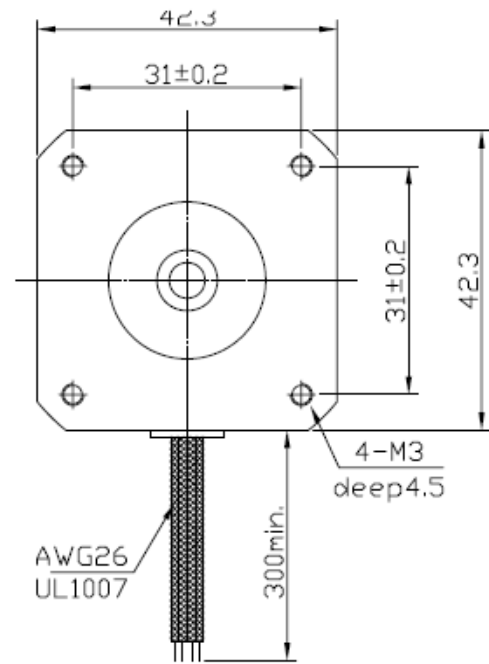
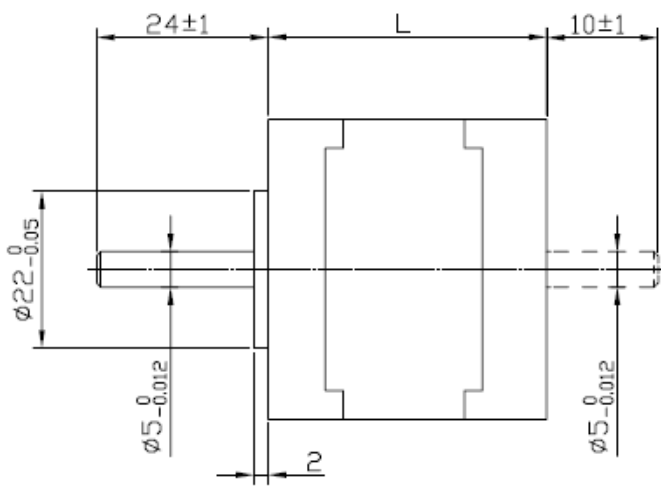

Wiring Diagram:

6 LEADS

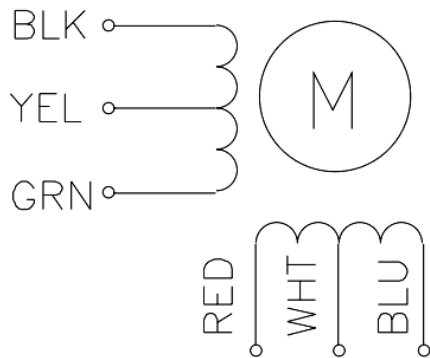

4 LEADS

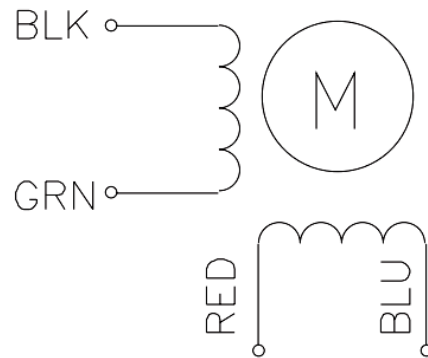

Matched Drivers:

2 Phase Stepper Motor Driver, Models: JK0220, JK0230